

- Tentative Specification
- Preliminary Specification
- Approval Specification

MODEL NO.: G150XGE
SUFFIX: L05

Customer:	
APPROVED BY	SIGNATURE
Name / Title _____	_____
Note	
Please return 1 copy for your confirmation with your signature and comments.	

Approved By	Checked By	Prepared By
yuhsiang.chang (張喻翔/514-10922) 2013-05-16 12:35:01 CST	clark.kuo (郭鐘亮/514-10921) 2013-05-13 07:23:58 CST	jason.mf.huang (黃名福/514-10919) 2013-05-11 15:13:42 CST

- CONTENTS -

REVISION HISTORY	-----	3
1. GENERAL DESCRIPTION	-----	4
1.1 OVERVIEW		
1.2 FEATURES		
1.3 APPLICATION		
1.4 GENERAL SPECIFICATIONS		
1.5 MECHANICAL SPECIFICATIONS		
2. ABSOLUTE MAXIMUM RATINGS	-----	6
2.1 ABSOLUTE RATINGS OF ENVIRONMENT		
2.2 ELECTRICAL ABSOLUTE RATINGS		
2.2.1 TFT LCD MODULE		
2.2.2 BACKLIGHT UNIT		
3. ELECTRICAL CHARACTERISTICS	-----	8
3.1 TFT LCD MODULE		
3.2 BACKLIGHT UNIT		
4. BLOCK DIAGRAM	-----	10
4.1 TFT LCD MODULE		
5. INPUT TERMINAL PIN ASSIGNMENT	-----	11
5.1 TFT LCD MODULE		
5.2 BACKLIGHT UNIT		
5.3 COLOR DATA INPUT ASSIGNMENT		
6. INTERFACE TIMING	-----	13
6.1 INPUT SIGNAL TIMING SPECIFICATIONS		
6.2 POWER ON/OFF SEQUENCE		
6.3 THE INPUT DATA FORMAT		
6.4 SCANNING DIRECTION		
7. OPTICAL CHARACTERISTICS	-----	17
7.1 TEST CONDITIONS		
7.2 OPTICAL SPECIFICATIONS		
8. RELIABILITY TEST CRITERIA	-----	21
9. PACKAGING	-----	22
9.1 PACKING SPECIFICATIONS		
9.2 PACKING METHOD		
9.3 UNPACKING METHOD		
10. DEFINITION OF LABELS	-----	24
11. PRECAUTIONS	-----	25
11.1 ASSEMBLY AND HANDLING PRECAUTIONS		
11.2 SAFETY PRECAUTIONS		
12. MECHANICAL CHARACTERISTICS	-----	26

REVISION HISTORY

Version	Date	Section	Description
Ver. 1.0	May 10, 2013	All	Preliminary Specification was first issued.

1. GENERAL DESCRIPTION

1.1 OVERVIEW

G150XGE-L05 is a 15.0" TFT Liquid Crystal Display module with LED Backlight units and 20 pins LVDS interface. This module supports 1024 x 768 XGA mode and can display 16.2M/262k colors.

The PSWG is to establish a set of displays with standard mechanical dimensions and select electrical interface requirements for an industry standard 15.0" XGA LCD panel and the LED driving device for Backlight is built in PCBA.

1.2 FEATURES

- XGA (1024 x 768 pixels) resolution
- DE (Data Enable) only mode
- LVDS Interface with 1pixel/clock
- PSWG (Panel Standardization Working Group)
- Wide operating temperature.
- RoHS compliance

1.3 APPLICATION

- TFT LCD Monitor
- Factory Application
- Amusement
- Vehicle

1.4 GENERAL SPECIFICATIONS

Item	Specification	Unit	Note
Active Area	304.1 (H) x 228.1(V) (15.0" diagonal)	mm	(1)
Bezel Opening Area	307.4(H) x 231.3(V)	mm	
Driver Element	a-Si TFT active matrix	-	-
Pixel Number	1024 x R.G.B x 768	pixel	-
Pixel Pitch	0.297(H) x 0.297(W)	mm	-
Pixel Arrangement	RGB vertical Stripe	-	-
Display Colors	16,194,277 / 262,144	color	-
Display Mode	Normally White	-	-
Surface Treatment	Hard Coating (3H), Anti-Glare (Haze 25)	-	-
Module Power Consumption	7.5	W	Typical

1.5 MECHANICAL SPECIFICATIONS

Item		Min.	Typ.	Max.	Unit	Note
Module Size	Horizontal(H)	326.0	326.5	327.0	mm	(1)
	Vertical(V)	253.0	253.5	254.0	mm	
	Depth(D)	-	11.5	12.0	mm	(1)(2)
Weight		-	1084.6	1134	g	-

Note (1) Please refer to the attached drawings for more information of front and back outline dimensions.

Note (2) The depth is without connector.

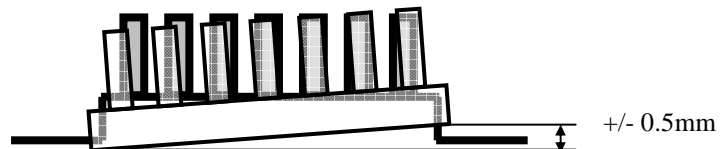

2. ABSOLUTE MAXIMUM RATINGS

2.1 ABSOLUTE RATINGS OF ENVIRONMENT

Item	Symbol	Value		Unit	Note
		Min.	Max.		
Operating Ambient Temperature	T _{OP}	-30	+70	°C	
Storage Temperature	T _{ST}	-40	+70	°C	

Note (1) Temperature and relative humidity range is shown in the figure below.

- (2) 90 %RH Max. (Ta ≤ 40°C).
- (3) Wet-bulb temperature should be 39°C Max. (Ta > 40°C).
- (4) No condensation.

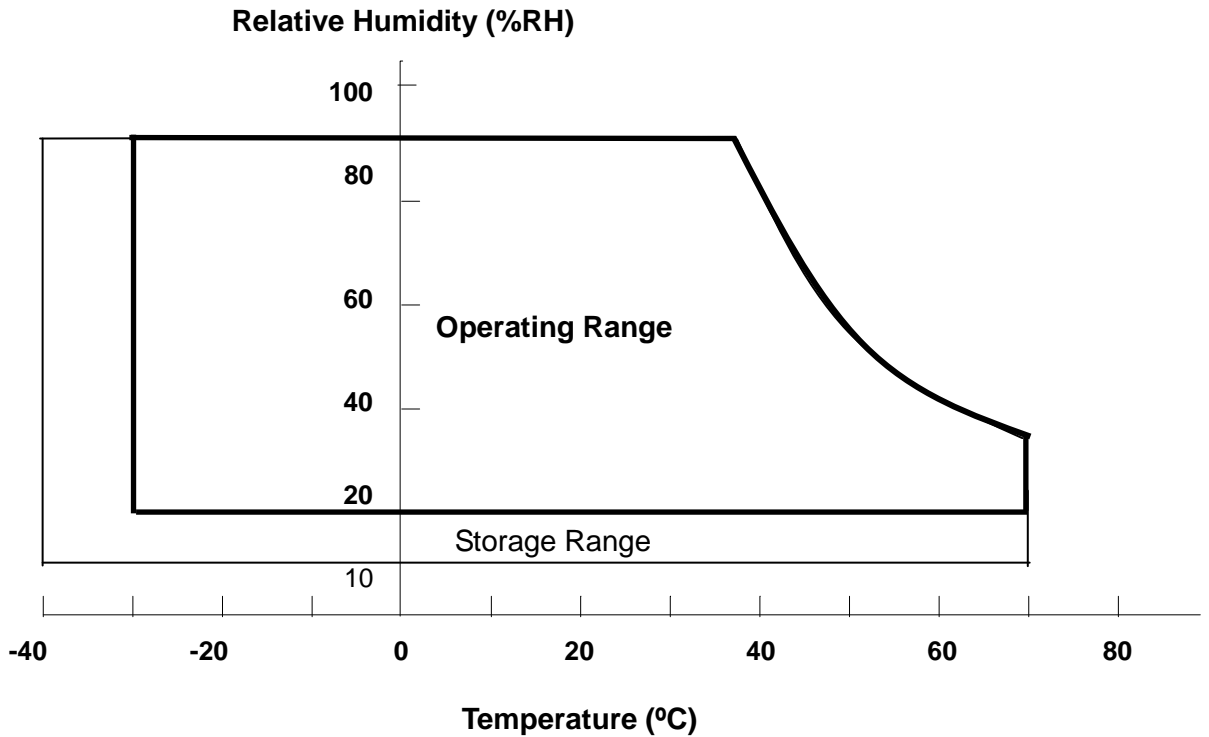

2.2 ELECTRICAL ABSOLUTE RATINGS

2.2.1 TFT LCD MODULE

Item	Symbol	Value		Unit	Note
		Min.	Max.		
Power Supply Voltage	VCC	-0.3	4	V	(1)

2.2.2 BACKLIGHT UNIT

Item	Symbol	Value		Unit	Note
		Min.	Max.		
Converter Voltage	V_i	-0.3	18	V	(1), (2)
Enable Voltage	EN	---	5.5	V	
Backlight Adjust	ADJ	---	5.5	V	

Note (1) Permanent damage to the device may occur if maximum values are exceeded. Function operation should be restricted to the conditions described under Normal Operating Conditions.

Note (2) Specified values are for lamp (Refer to 3.2 for further information).

3. ELECTRICAL CHARACTERISTICS

3.1 TFT LCD MODULE

Parameter	Symbol	Value			Unit	Note	
		Min.	Typ.	Max.			
Power Supply Voltage	V_{CC}	3.0	3.3	3.6	V	-	
Ripple Voltage	V_{RP}	-	-	100	mVp-p		
Rush Current	I_{RUSH}	-	-	2.0	A	(2)	
Power Supply Current	White	-	410	510	mA	(3)a	
	Black	-	590	690	mA	(3)b	
LVDS differential input voltage	V_{id}	200	-	600	mV		
LVDS common input voltage	V_{ic}	1.0	1.2	1.4	V		
Differential Input Voltage for LVDS Receiver Threshold	"H" Level	V_{IH}	-	-	100	mV	-
	"L" Level	V_{IL}	-100	-	-	mV	-
Terminating Resistor	R_T	-	100	-	Ohm	-	

Note (1) The module should be always operated within above ranges.

Note (2) Measurement Conditions:

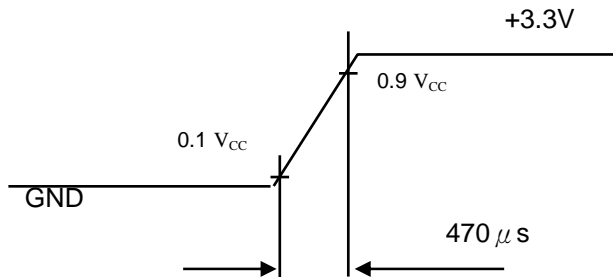
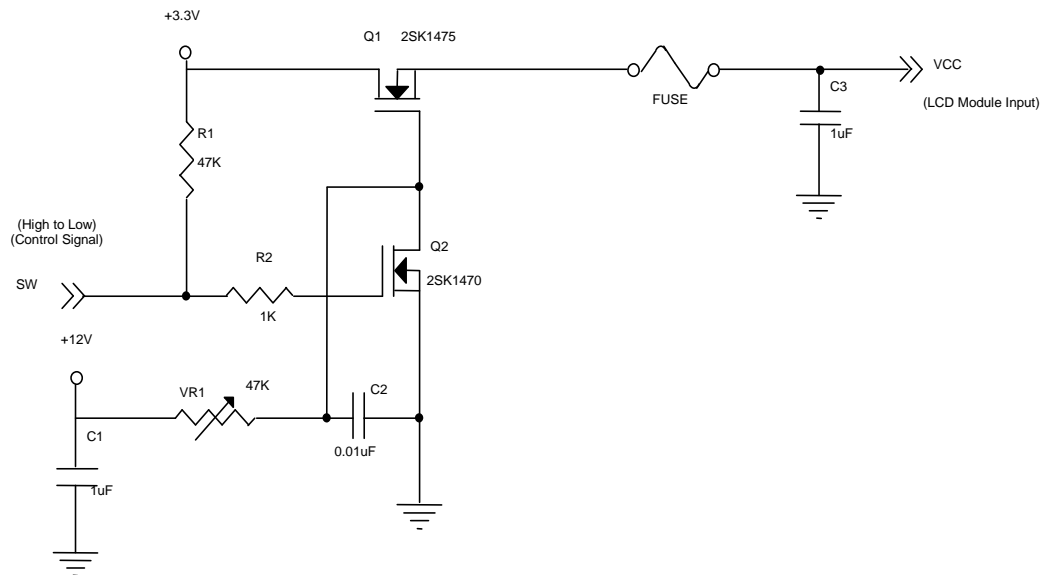

Note (3) The specified power supply current is under the conditions at $V_{DD} = 3.3V$, $T_a = 25 \pm 2 \text{ }^\circ\text{C}$, DC Current and $f_v = 60 \text{ Hz}$, whereas a power dissipation check pattern below is displayed.

a. White Pattern

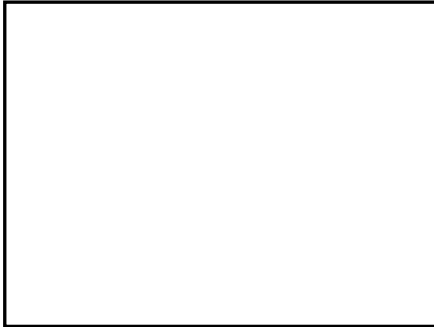

Active Area

b. Black Pattern

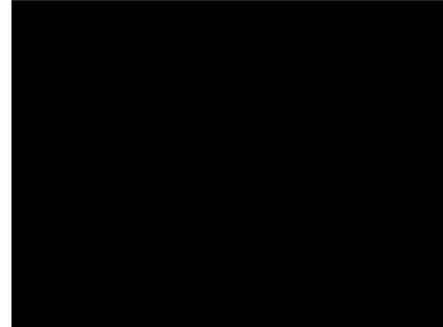

Active Area

3.2 BACKLIGHT UNIT

$T_a = 25 \pm 2 \text{ }^\circ\text{C}$

Parameter	Symbol	Value			Unit	Note	
		Min.	Typ.	Max.			
Converter Power Supply Voltage	V_i	10.8	12.0	13.2	V		
Converter Power Supply Current	I_i	0.45	0.4	0.37	A	@ $V_i = 12V$ (Duty 100%)	
Backlight Power Consumption	P_{BL}	-	--	4.9	W	@ $V_i = 12V$ (Duty 100%)	
EN Control Level	Backlight on	-	2.0	3.3	5.0	V	
	Backlight off	-	0	---	0.8	V	
PWM Control Level	PWM High Level	-	2.0	3.3	5.0	V	
	PWM Low Level	-	0	-	0.15	V	
PWM Control Duty Ratio	-	-	1	-	100	%	@200Hz
PWM Control Frequency	f_{PWM}	-	190	200	20k	Hz	(2)
LED Life Time	L_L	-	50,000	-	-	Hrs	(3)

Note (1) LED current is measured by utilizing a high frequency current meter as shown below:

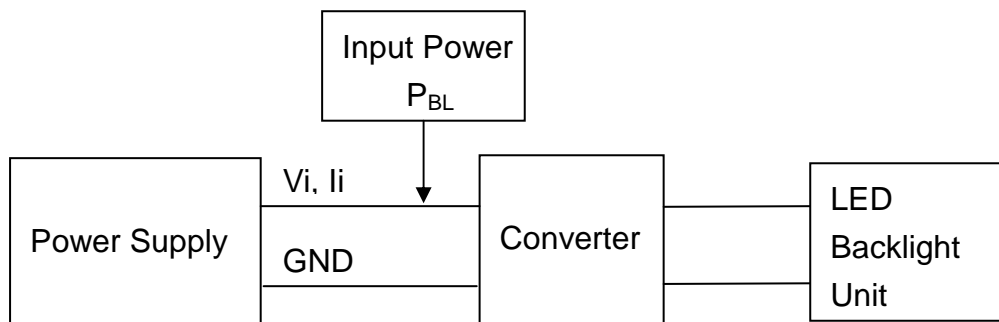

Note (2) At 20k Hz PWM control frequency, duty ratio range is restricted from 20% to 100%.

Note (3) The lifetime of LED is defined as the time when it continues to operate under the conditions at $T_a = 25 \pm 2 \text{ }^\circ\text{C}$ and Duty 100% until the brightness becomes $\leq 50\%$ of its original value. Operating LED under high temperature environment will reduce life time and lead to color shift.

4. BLOCK DIAGRAM
4.1 TFT LCD MODULE

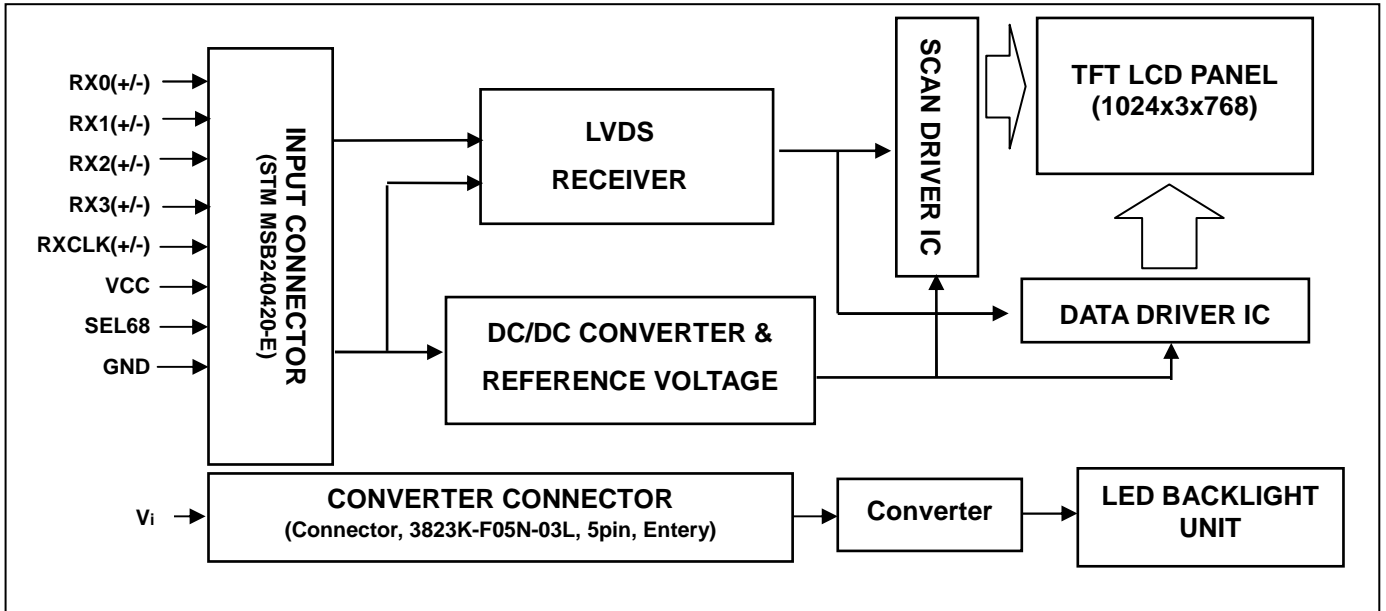

5. INPUT TERMINAL PIN ASSIGNMENT

5.1 TFT LCD MODULE

Pin No.	Symbol	Function	Polarity	Note
1	VCC	Power Supply +3.3V(typical)		
2	VCC	Power Supply +3.3V(typical)		
3	GND	Ground		
4	LR/UD	Reverse Scan Control H or NC = Normal Mode. L = Horizontal/ Vertical Reverse Scan.		
5	RX0-	LVDS Differential Data Input	Negative	
6	RX0+	LVDS Differential Data Input	Positive	
7	GND	Ground		
8	RX1-	LVDS Differential Data Input	Negative	
9	RX1+	LVDS Differential Data Input	Positive	
10	GND	Ground		
11	RX2-	LVDS Differential Data Input	Negative	
12	RX2+	LVDS Differential Data Input	Positive	
13	GND	Ground		
14	RXCLK-	LVDS Differential Data Input	Negative	
15	RXCLK+	LVDS Differential Data Input	Positive	
16	GND	Ground		
17	RX3-	LVDS Differential Data Input	Negative	
18	RX3+	LVDS Differential Data Input	Positive	
19	GND	Ground		
20	SEL68	LVDS 6/8 bit select function control, High → 6bit Input Mode Low or NC → 8bit Input Mode		Note (3)

Note (1) Connector Part No.: Entery 3804K-F20N-10L or equivalent.

Note (2) User's connector Part No.: Entery H204K-D20N-02B or equivalent.

Note (3) "Low" stands for 0V. "High" stands for 3.3V. "NC" stands for "No Connection".

5.2 BACKLIGHT UNIT(Converter connector pin)

Pin	Symbol	Description	Remark
1	V_i	Converter input voltage	12V
2	V_{GND}	Converter ground	Ground
3	EN	Enable pin	3.3V
4	ADJ	Backlight Adjust	PWM Dimming (Hi: 3.3V _{DC} , Lo: 0V _{DC})
5	NC	Not Connect	

Note (1) Connector Part No.: 3808K-F05N-03L (Entery) or equivalent.

Note (2) User's connector Part No.: 3808K-F05N-03L (Entery) or equivalent.

5.3 COLOR DATA INPUT ASSIGNMENT

The brightness of each primary color (red, green and blue) is based on the 8-bit gray scale data input for the color. The higher the binary input the brighter the color. The table below provides the assignment of color versus data input.

Color		Data Signal																							
		Red								Green								Blue							
		R7	R6	R5	R4	R3	R2	R1	R0	R7	R6	G5	G4	G3	G2	G1	G0	R7	R6	B5	B4	B3	B2	B1	B0
Basic Colors	Black	0	0	0	0	0	0	0	0	0	0	0	0	0	0	0	0	0	0	0	0	0	0	0	0
	Red	1	1	1	1	1	1	1	1	0	0	0	0	0	0	0	0	0	0	0	0	0	0	0	0
	Green	0	0	0	0	0	0	0	0	0	1	1	1	1	1	1	1	0	0	0	0	0	0	0	0
	Blue	0	0	0	0	0	0	0	0	0	0	0	0	0	0	0	0	1	1	1	1	1	1	1	1
	Cyan	0	0	0	0	0	0	0	0	1	1	1	1	1	1	1	1	1	1	1	1	1	1	1	1
	Magenta	1	1	1	1	1	1	1	1	0	0	0	0	0	0	0	0	1	1	1	1	1	1	1	1
	Yellow	1	1	1	1	1	1	1	1	1	1	1	1	1	1	1	1	0	0	0	0	0	0	0	0
	White	1	1	1	1	1	1	1	1	1	1	1	1	1	1	1	1	1	1	1	1	1	1	1	1
Gray Scale Of Red	Red(0) / Dark	0	0	0	0	0	0	0	0	0	0	0	0	0	0	0	0	0	0	0	0	0	0	0	
	Red(1)	0	0	0	0	0	0	0	1	0	0	0	0	0	0	0	0	0	0	0	0	0	0	0	
	Red(2)	0	0	0	0	0	0	1	0	0	0	0	0	0	0	0	0	0	0	0	0	0	0	0	
	⋮	⋮	⋮	⋮	⋮	⋮	⋮	⋮	⋮	⋮	⋮	⋮	⋮	⋮	⋮	⋮	⋮	⋮	⋮	⋮	⋮	⋮	⋮	⋮	
	⋮	⋮	⋮	⋮	⋮	⋮	⋮	⋮	⋮	⋮	⋮	⋮	⋮	⋮	⋮	⋮	⋮	⋮	⋮	⋮	⋮	⋮	⋮	⋮	
	Red(252)	1	1	1	1	1	1	0	1	0	0	0	0	0	0	0	0	0	0	0	0	0	0	0	
	Red(252)	1	1	1	1	1	1	1	0	0	0	0	0	0	0	0	0	0	0	0	0	0	0	0	
	Red(252)	1	1	1	1	1	1	1	1	0	0	0	0	0	0	0	0	0	0	0	0	0	0	0	
Gray Scale Of Green	Green(0)/Dark	0	0	0	0	0	0	0	0	0	0	0	0	0	0	0	0	0	0	0	0	0	0	0	
	Green(1)	0	0	0	0	0	0	0	0	0	0	0	0	0	0	0	1	0	0	0	0	0	0	0	
	Green(2)	0	0	0	0	0	0	0	0	0	0	0	0	0	0	1	0	0	0	0	0	0	0	0	
	⋮	⋮	⋮	⋮	⋮	⋮	⋮	⋮	⋮	⋮	⋮	⋮	⋮	⋮	⋮	⋮	⋮	⋮	⋮	⋮	⋮	⋮	⋮	⋮	
	⋮	⋮	⋮	⋮	⋮	⋮	⋮	⋮	⋮	⋮	⋮	⋮	⋮	⋮	⋮	⋮	⋮	⋮	⋮	⋮	⋮	⋮	⋮	⋮	
	Green(252)	0	0	0	0	0	0	0	0	1	1	1	1	1	1	0	1	0	0	0	0	0	0	0	
	Green(252)	0	0	0	0	0	0	0	0	1	1	1	1	1	1	1	0	0	0	0	0	0	0	0	
	Green(252)	0	0	0	0	0	0	0	0	1	1	1	1	1	1	1	1	0	0	0	0	0	0	0	
Gray Scale Of Blue	Blue(0) / Dark	0	0	0	0	0	0	0	0	0	0	0	0	0	0	0	0	0	0	0	0	0	0	0	
	Blue(1)	0	0	0	0	0	0	0	0	0	0	0	0	0	0	0	0	0	0	0	0	0	0	1	
	Blue(2)	0	0	0	0	0	0	0	0	0	0	0	0	0	0	0	0	0	0	0	0	0	0	1	
	⋮	⋮	⋮	⋮	⋮	⋮	⋮	⋮	⋮	⋮	⋮	⋮	⋮	⋮	⋮	⋮	⋮	⋮	⋮	⋮	⋮	⋮	⋮	⋮	
	⋮	⋮	⋮	⋮	⋮	⋮	⋮	⋮	⋮	⋮	⋮	⋮	⋮	⋮	⋮	⋮	⋮	⋮	⋮	⋮	⋮	⋮	⋮	⋮	
	Blue(252)	0	0	0	0	0	0	0	0	0	0	0	0	0	0	0	0	1	1	1	1	1	1	0	
	Blue(252)	0	0	0	0	0	0	0	0	0	0	0	0	0	0	0	0	1	1	1	1	1	1	0	
	Blue(252)	0	0	0	0	0	0	0	0	0	0	0	0	0	0	0	0	1	1	1	1	1	1	1	

Note (1) 0: Low Level Voltage, 1: High Level Voltage

6. INTERFACE TIMING

6.1 INPUT SIGNAL TIMING SPECIFICATIONS

The input signal timing specifications are shown as the following table and timing diagram.

Signal	Item	Symbol	Min.	Typ.	Max.	Unit	Note
DCLK	Pixel Clock	$1/T_C$	53.35	65	80	MHz	-
DE	Vertical Total Time	T_V	780	806	1200	T_H	-
	Vertical Address Time	T_{VD}	768	768	768	T_H	-
	Horizontal Total Time	T_H	1140	1344	1600	T_C	-
	Horizontal Address Time	T_{HD}	1024	1024	1024	T_C	-

Note (1) Because this module is operated by DE only mode, Hsync and Vsync input signals should be set to low logic level or ground. Otherwise, this module would operate abnormally.

INPUT SIGNAL TIMING DIAGRAM

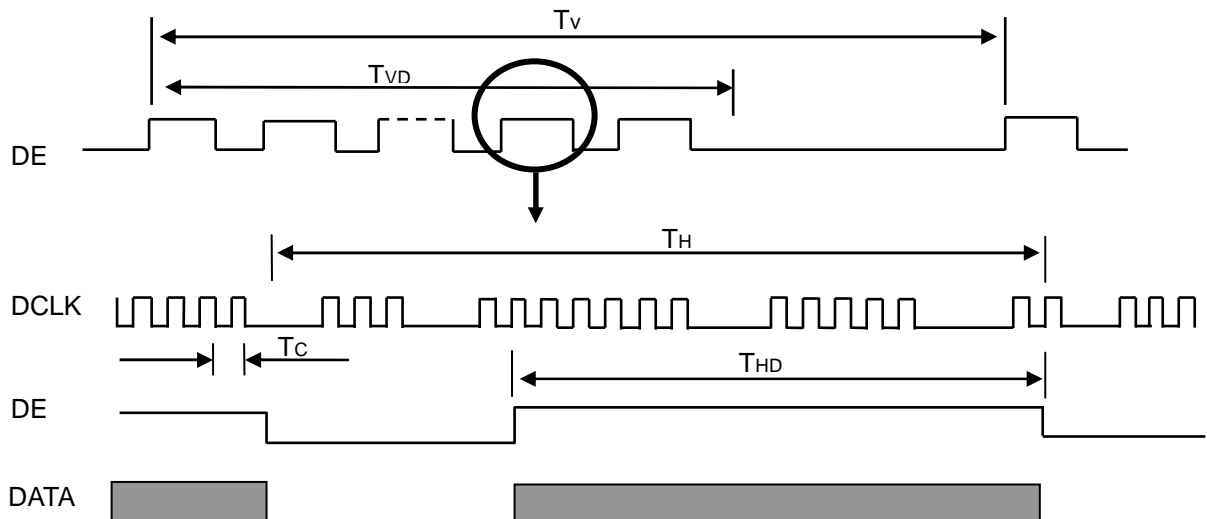

TIMING DIAGRAM of LVDS

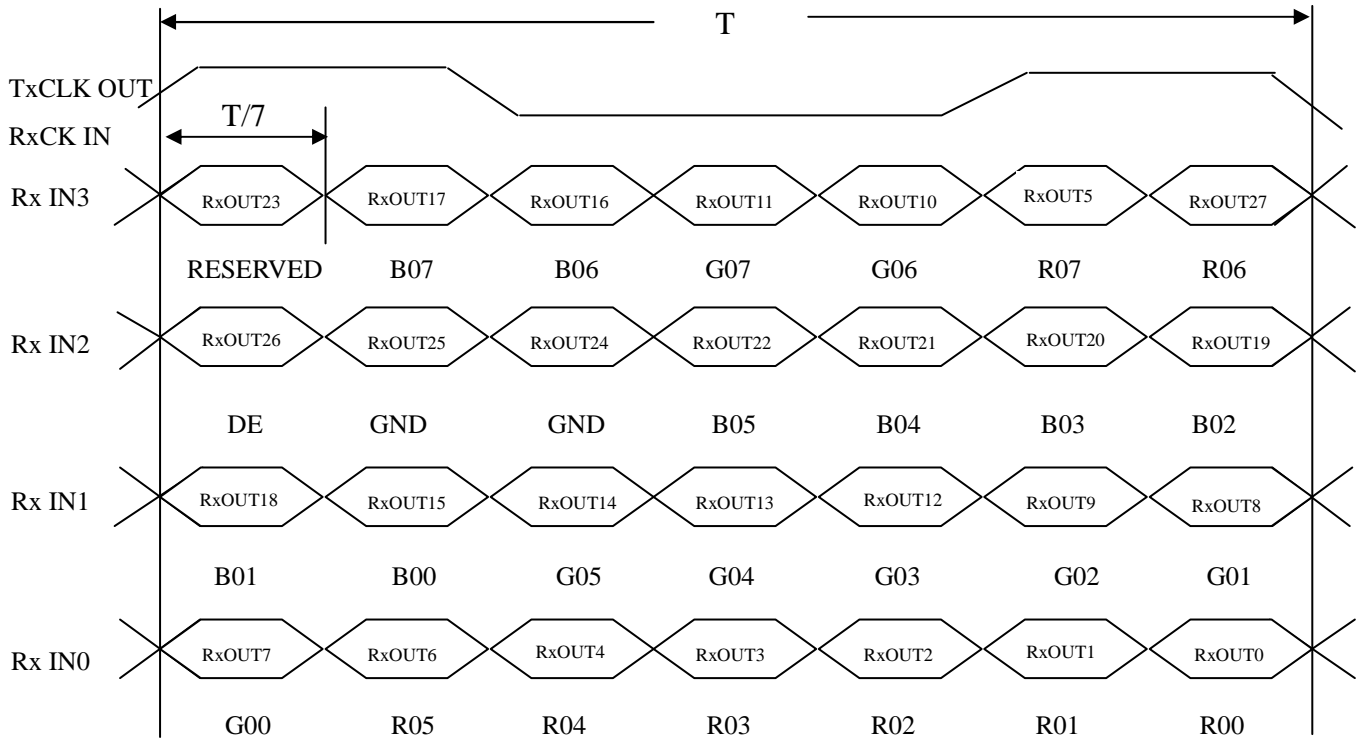

6.2 POWER ON/OFF SEQUENCE

To prevent a latch-up or DC operation of LCD assembly, the power on/off sequence should be as the diagram below.

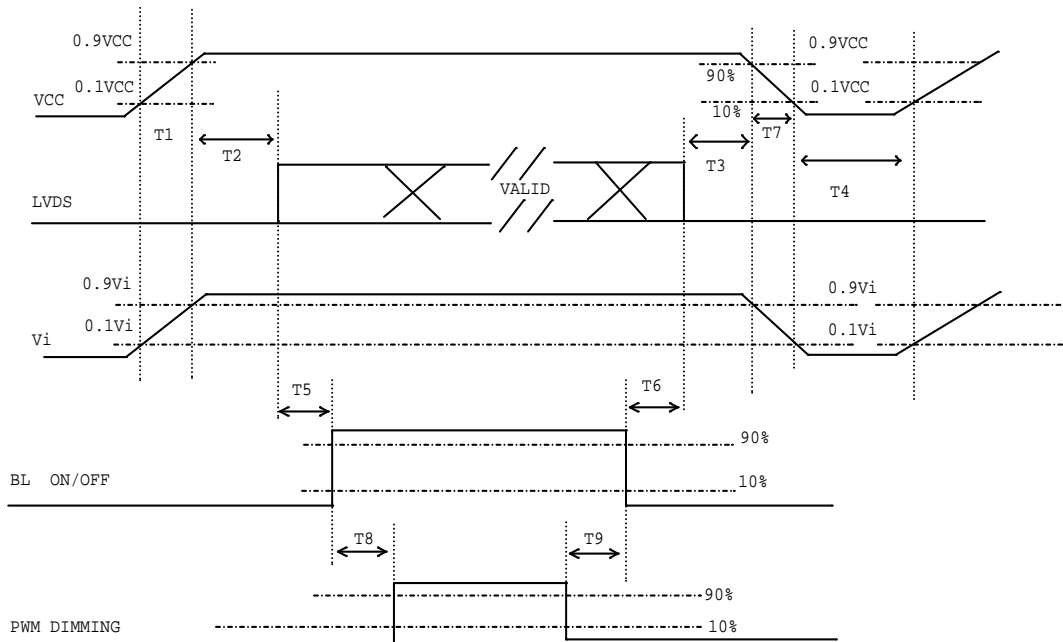

Power ON/OFF sequence

Note (1) Please avoid floating state of interface signal at invalid period.

Note (2) When the interface signal is invalid, be sure to pull down the power supply of LCD VCC to 0 V.

Note (3) The Backlight converter power must be turned on after the power supply for the logic and the interface signal is valid. The Backlight converter power must be turned off before the power supply for the logic and the interface signal is invalid.

Parameter	Value			Units
	Min	Typ	Max	
T1	0.5	-	10	ms
T2	0	-	50	ms
T3	0	-	50	ms
T4	500	-	-	ms
T5	200	-	-	ms
T6	200	-	-	ms
T7	5	-	300	ms
T8	10	-	-	ms
T9	10	-	-	ms

6.4 SCANNING DIRECTION

The following figures show the image see from the front view. The arrow indicates the direction of scan.

Fig.1 Normal Scan



Fig.2 Reverse Scan



Fig. 1 Normal scan (pin 4, LR/UD = High or NC)

Fig. 2 Reverse scan (pin 4, LR/UD = Low)

7. OPTICAL CHARACTERISTICS

7.1 TEST CONDITIONS

Item	Symbol	Value	Unit
Ambient Temperature	Ta	25±2	°C
Ambient Humidity	Ha	50±10	%RH
Supply Voltage	V _{CC}	3.3	V
Input Signal	According to typical value in "3. ELECTRICAL CHARACTERISTICS"		
Converter Voltage	V _i	12	V
Converter Duty		100%	

7.2 OPTICAL SPECIFICATIONS

The relative measurement methods of optical characteristics are shown in 7.2. The following items should be measured under the test conditions described in 7.1 and stable environment shown in Note (5).

Item	Symbol	Condition	Min.	Typ.	Max.	Unit	Note		
Color Chromaticity	Red	$\theta_x=0^\circ, \theta_y=0^\circ$ CS-1000T	Typ - 0.05	0.604	Typ+ 0.05	-	(1), (5)		
				Ry				0.356	
	Green			Gx				0.338	
				Gy				0.590	
	Blue			Bx				0.148	
				By				0.098	
	White			Wx				0.313	
				Wy				0.329	
Center Luminance of White	L _C		200	250		cd/m ²	(4), (5)		
Contrast Ratio	CR		450	700		-	(2), (5)		
Response Time	T _R	$\theta_x=0^\circ, \theta_y=0^\circ$	-	5	10	ms	(3)		
	T _F			11	16				
White Variation	δW	$\theta_x=0^\circ, \theta_y=0^\circ$ USB2000	-	1.25	1.33	-	(5), (6)		
Viewing Angle	Horizontal	CR ≥ 10 USB2000	70	80	-	Deg.	(1), (5)		
				θ _{x-}	80			-	
	Vertical			θ _{y+}	50			70	-
				θ _{y-}	50			70	-

Note (1) Definition of Viewing Angle (θ_x, θ_y):

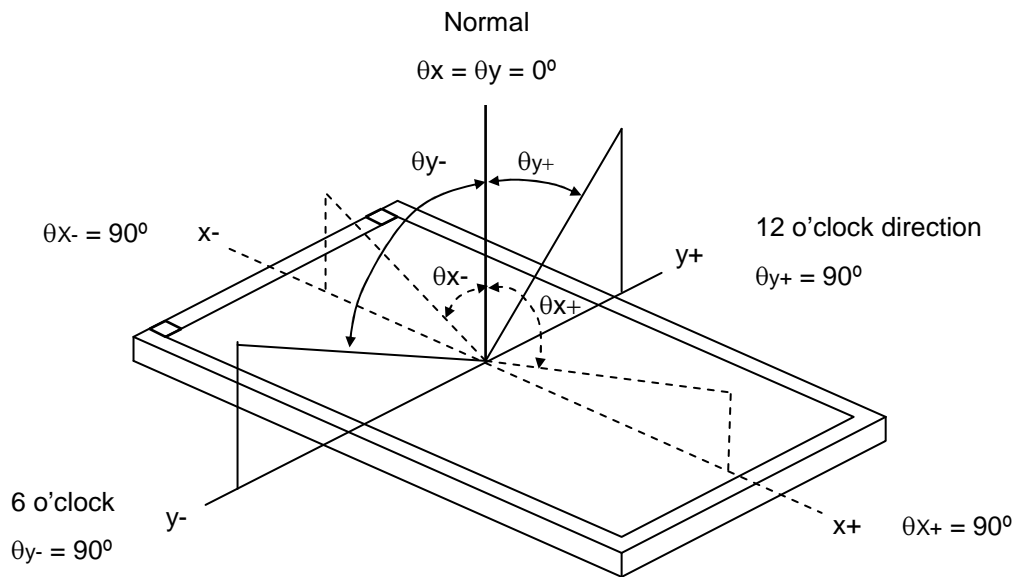

Note (2) Definition of Contrast Ratio (CR):

The contrast ratio can be calculated by the following expression.

$$\text{Contrast Ratio (CR)} = L_{255} / L_0$$

L255: Luminance of gray level 255

L0: Luminance of gray level 0

$$\text{CR} = \text{CR} (5)$$

CR (X) is corresponding to the Contrast Ratio of the point X at Figure in Note (6).

Note (3) Definition of Response Time (T_R, T_F):

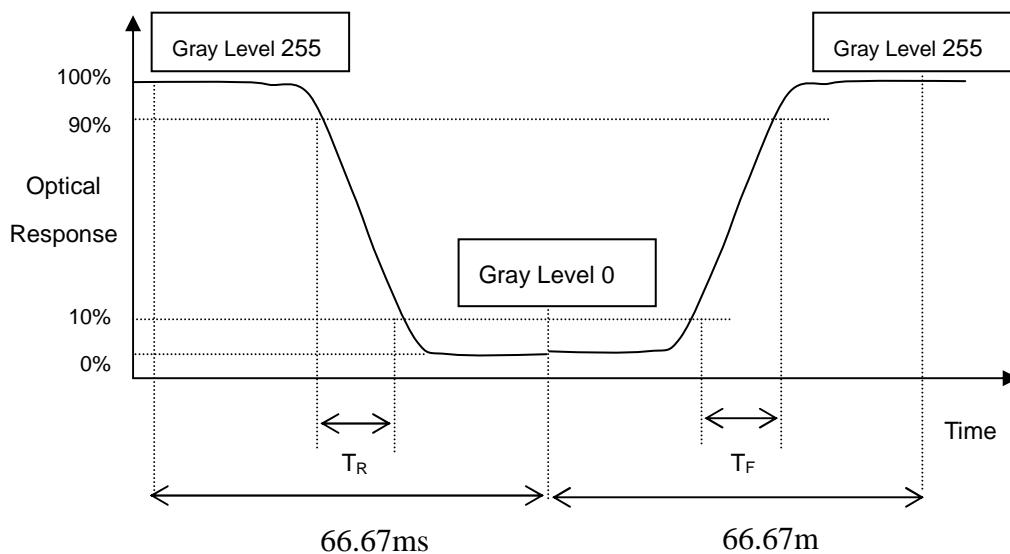

Note (4) Definition of Luminance of White (L_C):

Measure the luminance of gray level 255 at center point

$$L_C = L(5)$$

$L(x)$ is corresponding to the luminance of the point X at Figure in Note (6).

Note (5) Measurement Setup:

The LCD module should be stabilized at given temperature for 20 minutes to avoid abrupt temperature change during measuring. In order to stabilize the luminance, the measurement should be executed after lighting Backlight for 20 minutes in a windless room.

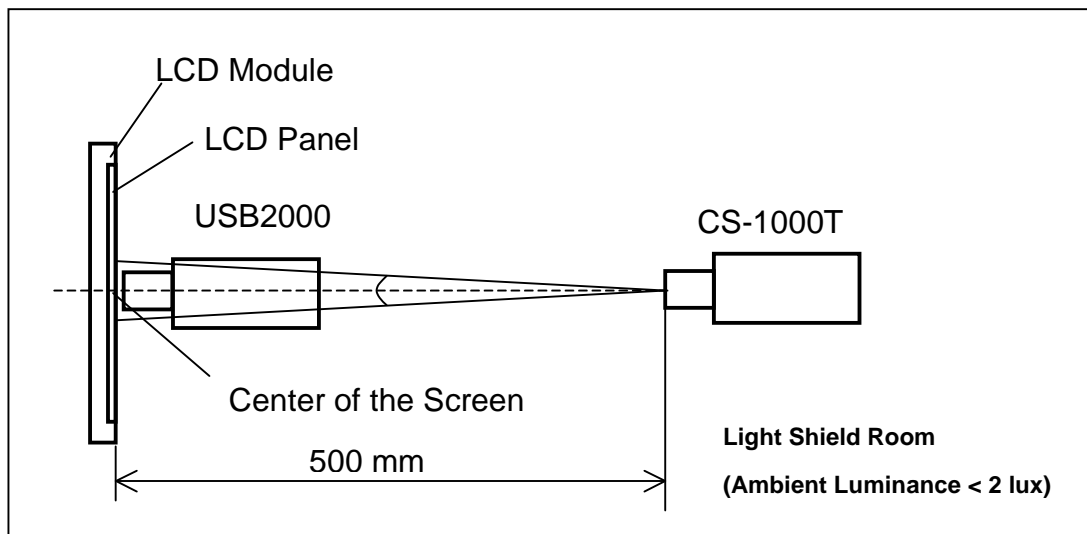

Note (6) Definition of White Variation (δW):

Measure the luminance of gray level 63 (255) at 9 points

$$\delta W = \frac{\text{Maximum [L (1), L (2), L (3), L (4), L (5) , L (6), L (7), L (8), L (9)]}}{\text{Minimum [L (1), L (2), L (3), L (4), L (5) , L (6), L (7), L (8), L (9)]}}$$

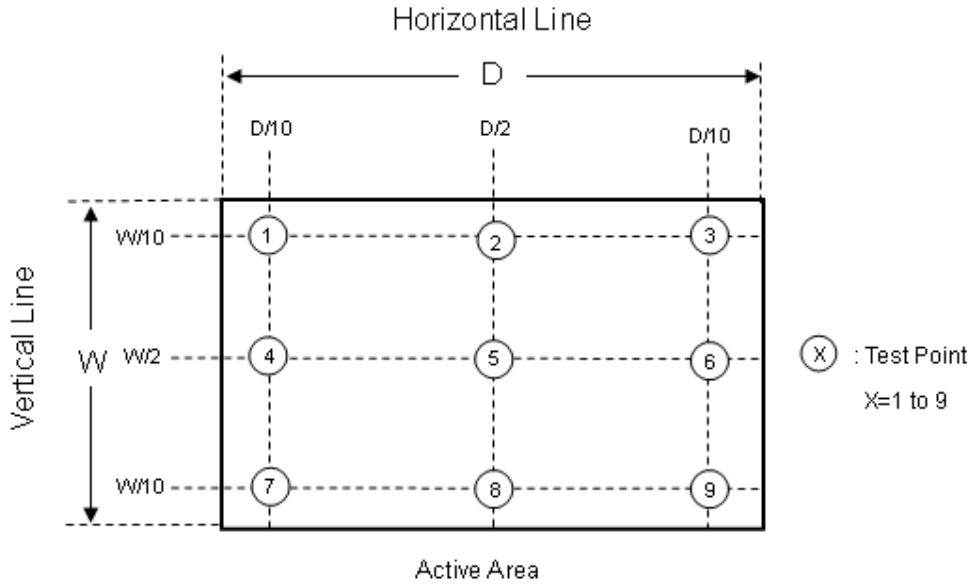

8. RELIABILITY TEST CRITERIA

Test Item	Test Condition	Note
High Temperature Storage Test	70°C, 240 hours	(1), (2)
Low Temperature Storage Test	-40°C, 240 hours	
Thermal Shock Storage Test	-30°C, 0.5 hour ↔ 70°C, 0.5 hour; 100cycles, 1 hour/cycle)	
High Temperature Operation Test	70°C, 240 hours	
Low Temperature Operation Test	-30°C, 240 hours	
High Temperature & High Humidity Operation Test	60°C, RH 90%, 240 hours	
ESD Test (Operation)	150pF, 330Ω, 1 sec/cycle Condition 1 : panel contact, ±8 KV Condition 2 : panel non-contact ±15 KV	(2)
Shock (Non-Operating)	50G, 11ms, half sine wave, 1 time for ± X, ± Y, ± Z direction	(2), (3)
Vibration (Non-Operating)	1.5G, 10 ~ 300 Hz sine wave, 10 min/cycle, 3 cycles each X, Y, Z direction	(2), (3)

Note (1) No condensation of water.

Note (2) No display malfunction.

Note (3) At testing Vibration and Shock, the fixture in holding the module has to be hard and rigid enough so that the module would not be twisted or bent by the fixture.

Note (4) Temperature of panel display surface area should be 90°C Max.

9. PACKAGING

9.1 PACKING SPECIFICATIONS

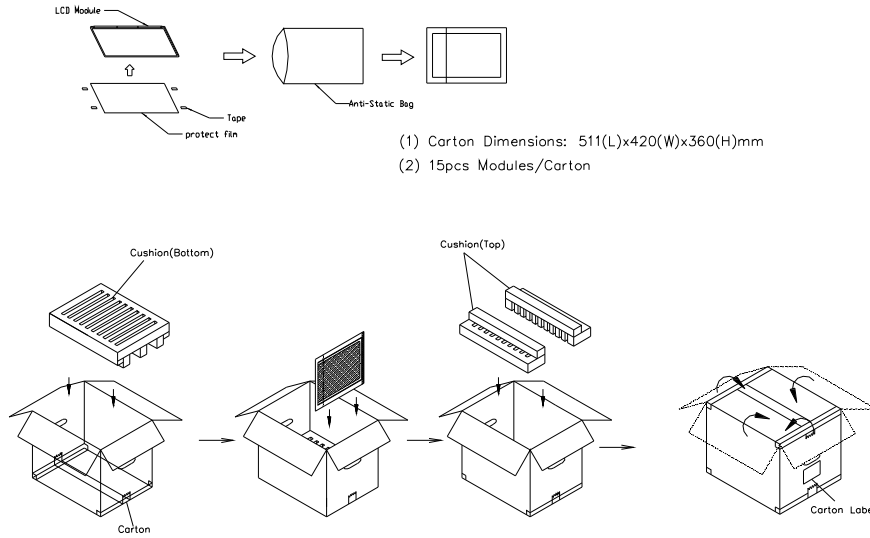

9.2 PACKING Method

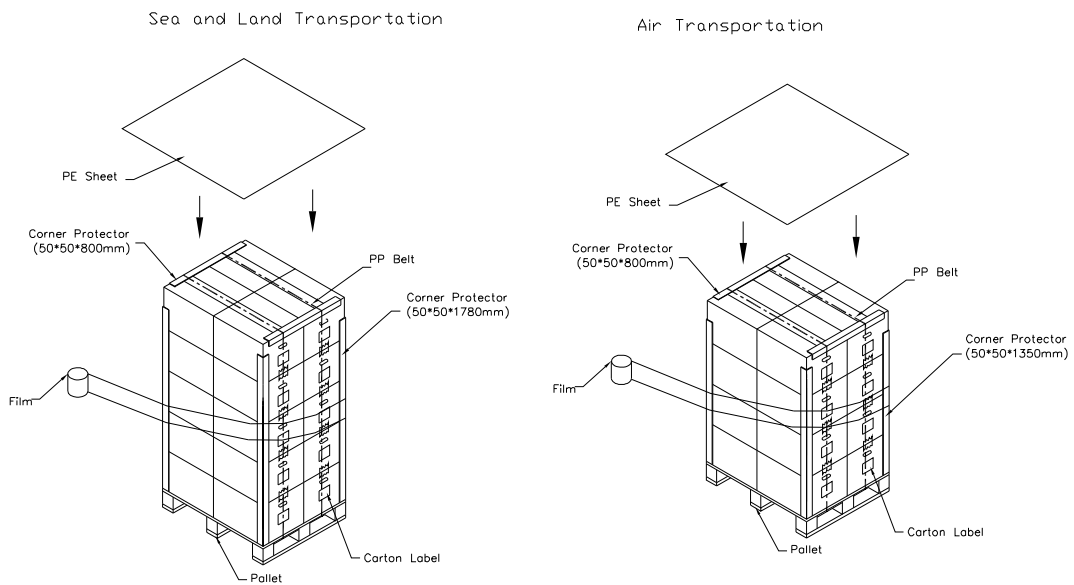

9.3 UN-PACKING Method

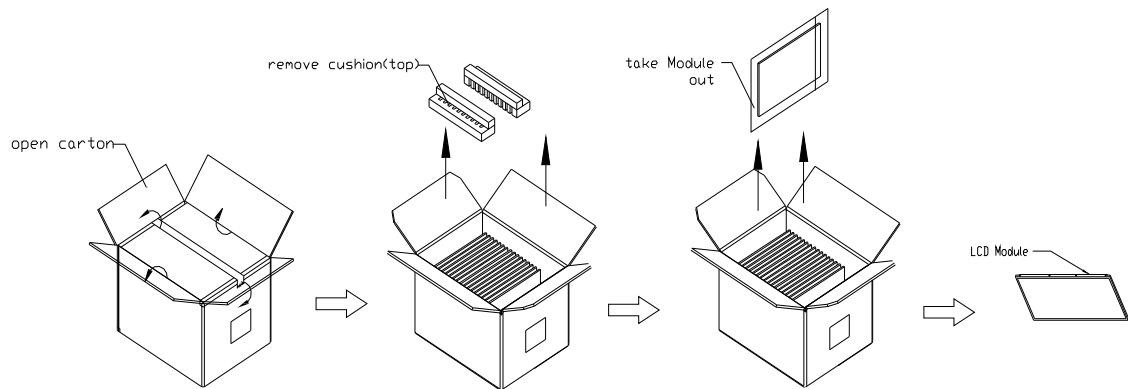
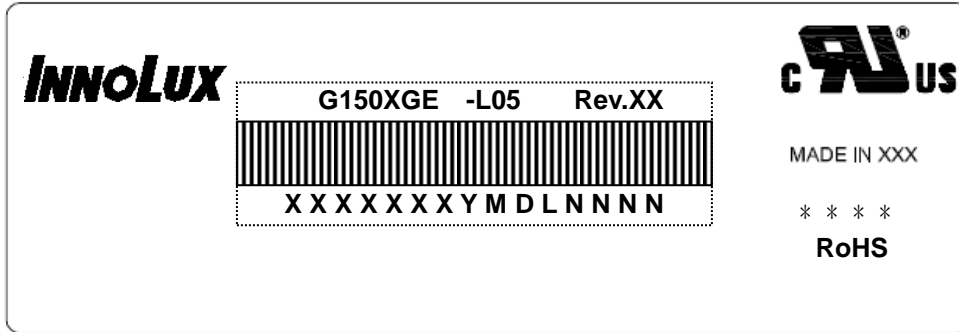

Figure. 9-3 UN-Packing method

10. DEFINITION OF LABELS

10.1 INX MODULE LABEL

The barcode nameplate is pasted on each module as illustration, and its definitions are as following explanation.



- (a) Model Name: G150XGE -L05
- (b) Revision: Rev. XX, for example: A1, B1, C1, C2 ...etc.
- (c) * * * * : Factory ID
- (d) Serial ID: X X X X X X X Y M D X N N N N

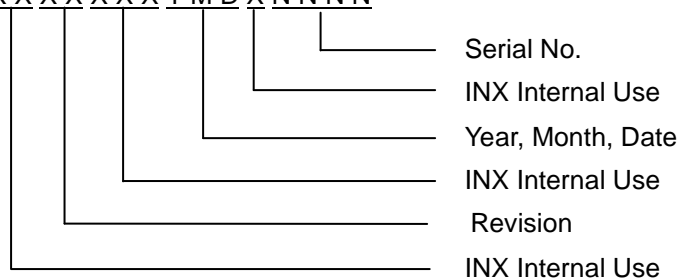

Serial ID includes the information as below:

- (a) Manufactured Date: Year: 1~9, for 2011~2019
 Month: 1~9, A~C, for Jan. ~ Dec.
 Day: 1~9, A~Y, for 1st to 31st, exclude I , O and U
- (b) Revision Code: cover all the change
- (c) Serial No.: Manufacturing sequence of product

11. PRECAUTIONS

11.1 ASSEMBLY AND HANDLING PRECAUTIONS

- (1) Do not apply rough force such as bending or twisting to the module during assembly.
- (2) To assemble or install module into user's system can be only in clean working areas. The dust and oil may cause electrical short or worsen the polarizer.
- (3) It's not permitted to have pressure or impulse on the module because the LCD panel and Backlight will be damaged.
- (4) Always follow the correct power sequence when LCD module is connecting and operating. This can prevent damage to the CMOS LSI chips during latch-up.
- (5) Do not pull the I/F connector in or out while the module is operating.
- (6) Do not disassemble the module.
- (7) Use a soft dry cloth without chemicals for cleaning, because the surface of polarizer is very soft and easily scratched.
- (8) It is dangerous that moisture come into or contacted the LCD module, because moisture may damage LCD module when it is operating.
- (9) High temperature or humidity may reduce the performance of module. Please store LCD module within the specified storage conditions.
- (10) When ambient temperature is lower than 10°C may reduce the display quality. For example, the response time will become slowly.
- (11) Do not keep same pattern in a long period of time. It may cause image sticking on LCD.

11.2 SAFETY PRECAUTIONS

- (1) Do not disassemble the module or insert anything into the Backlight unit.
- (2) If the liquid crystal material leaks from the panel, it should be kept away from the eyes or mouth. In case of contact with hands, skin or clothes, it has to be washed away thoroughly with soap.
- (3) After the module's end of life, it is not harmful in case of normal operation and storage.

12. MECHANICAL CHARACTERISTICS

